

Cryptic Species in the *Anopheles (Nyssorhynchus) albitarsis* (Diptera: Culicidae) Complex: Incongruence Between Random Amplified Polymorphic DNA-Polymerase Chain Reaction Identification and Analysis of Mitochondrial DNA *COI* Gene Sequences

M. A. LEHR,¹ C. W. KILPATRICK,¹ R. C. WILKERSON,² AND J. E. CONN³

Ann. Entomol. Soc. Am. 98(6): 908–917 (2005)

ABSTRACT Random amplified polymorphic DNA (RAPD) diagnostic bands are one tool used to differentiate cryptic mosquito species in the *Anopheles albitarsis* Complex. Monophyly of four species (*A. albitarsis* Lynch-Arribálzaga, *A. albitarsis* B, *A. deaneorum* Rosa-Freitas, and *A. marajoara* Galvão & Damasceno) currently identified with the RAPD technique was assessed using sequences of the cytochrome oxidase I (*COI*) mitochondrial DNA (mtDNA) gene. Maximum parsimony, maximum likelihood, and Bayesian analyses support monophyly for *A. albitarsis* s.s., *A. albitarsis* B, and *A. deaneorum*. *Anopheles marajoara*, as identified by RAPD banding patterns, was either polyphyletic or paraphyletic in all phylogenetic analyses. The phylogenetic pattern and within-species genetic distances observed in *A. marajoara* suggest the existence of a previously unidentified species (species E) in northern Brazil and Venezuela. Diagnostic RAPD bands were unable to distinguish between *A. marajoara* and species E, probably because of the low number of correlated bands used to identify species and weaknesses of the RAPD technique, in particular, violations of the untested assumption of homology of comigrating bands. *A. marajoara* (even without species E) is paraphyletic with respect to *A. deaneorum*; if *A. deaneorum* is a separate species from *A. marajoara*, then *A. marajoara* may consist of two or more species in Amazonian Brazil. Based on mtDNA *COI* sequences, there are at least four phylogenetic species within the *Albitarsis* Complex: *A. albitarsis* s.s., *A. albitarsis* B, *A. marajoara*, and species E; the species status of *A. deaneorum* is ambiguous.

KEY WORDS cryptic species, *Anopheles albitarsis* s.l., mtDNA *COI* gene, RAPD-PCR

RANDOM AMPLIFIED POLYMORPHIC DNA (RAPD) analysis (Welsh and McClelland 1990, Williams et al. 1990) is a polymerase chain reaction (PCR)-based technique that uses a single, short oligonucleotide primer of arbitrary sequence to produce amplified product. RAPD-PCR allows a more random sample of the genome (Black 1993) with rapid production of large amounts of genetic information (Zhivotovsky 1999). RAPD-PCR has been a widely used tool among species in the genus *Anopheles* for population genetics studies (Manguin et al. 1999, Posso et al. 2003) and to differentiate cryptic mosquito species, including *Anopheles gambiae* Giles (Wilkerson et al. 1993), *A. minimus* Theobald (Sucharit and Komalamisra 1997, Kengne et al. 2001), and *A. dirus* Peyton & Harrison (Manguin et al. 2002).

Nevertheless, there have been technical (Riedy et al. 1992, Muralidharan and Wakeland 1993, Schierwater and Ender 1993) and theoretical problems noted

with RAPDs (Black 1993, Clark and Lanigan 1993, Lynch and Milligan 1994). A common assumption is that comigrating bands represent homologous loci. Comparisons of homologous bands for inferring phylogenetic relationships, however, may be misleading because amplified fragments of similar size from different species may not be derived from the same loci and not all RAPD fragments within the same amplification pattern are independent (van de Zande and Bijlsma 1995).

Anopheles (Nyssorhynchus) albitarsis Lynch-Arribálzaga is a Neotropical species complex that includes at least four cryptic species (Rosa-Freitas et al. 1990; Wilkerson et al. 1995a, b), only some of which are documented malaria vectors (Wilkerson et al. 2005). *Anopheles deaneorum* Rosa-Freitas is the only species said to be consistently identified using morphological characters (Rosa-Freitas et al. 1998). Because of the lack of morphological differentiation among the cryptic members of the complex, species identification in the field frequently relies on the presumed geographical distribution of a species (Rosa-Freitas et al. 1998). The evidence that members of the *Albitarsis* Complex occur sympatrically in some locations (Kreutzer et al. 1976; Steiner et al. 1982; Narang et al. 1993; Wilkerson

¹ Department of Biology, 120A Marsh Life Sciences Bldg., University of Vermont, Burlington, VT 05405.

² Smithsonian Institution, Walter Reed Biosystematics Unit, Museum Support Center, MRC 534, Washington, DC 20560.

³ Wadsworth Center, Griffin Laboratory, New York State Department of Health, 5668 State Farm Rd., Slingerlands, NY 12159.

Table 1. Summary of collection localities for *A. albitalarsis* s.l. and outgroups *A. braziliensis* and *A. darlingi*

Map ref.	State/Province	Locality (coordinates)	RAPD-PCR species ^a
	Brazil		
1	Amazonas	Manaus (2° 53' S, 60° 15' W)	<i>A. marajoara</i> (C10)
2	Bahia	Itaquara (13° 26' S, 39° 56' W)	<i>A. albitalarsis</i> B (B1, B4, B5)
3	Ceará	Fortaleza (3° 43' S, 38° 30' W)	<i>A. albitalarsis</i> B (B3)
4	Mato Grosso	Matupa/Peixoto de Azevedo (10° 23' S, 54° 54' W)	<i>A. marajoara</i> (C7, C8) <i>A. deaneorum</i> (D2)
5	Pará	Itaituba (4° 15' S, 55° 59' W)	<i>A. marajoara</i> (C2, C3, C4, C5, C6)
6		Timboteua (0° 56' S, 47° 20' W)	<i>A. albitalarsis</i> B (B6)
7		Ilha de Marajó ^b (0° 46' S, 48° 31' W)	<i>A. marajoara</i> (C1)
8	Rondônia	Ariquemes (9° 56' S, 63° 04' W)	<i>A. marajoara</i> (C9)
9		Guajará-Mirim ^c (10° 50' S, 65° 20' W)	<i>A. deaneorum</i> (D1, D5, D6)
10	Roraima	Boa Vista (2° 49' N, 60° 40' W)	<i>A. marajoara</i> (C11, C12, C13)
11	Santa Catarina	Macaranduba (26° 35' S, 48° 58' W)	<i>A. albitalarsis</i> s.s. (A3)
12	São Paulo	6 km SW Registro (24° 37' S, 47° 53' W)	<i>A. albitalarsis</i> s.s. (A2) <i>A. albitalarsis</i> B (B2)
	Amapá	Macapá (0° 2' S, 51° 11' W)	<i>A. braziliensis</i>
	Amapá	Macapá (0° 2' S, 51° 11' W)	<i>A. darlingi</i>
	Argentina		
13	Buenos Aires	Baradero ^d (33° 48' S, 59° 30' W)	<i>A. albitalarsis</i> s.s. (A1, A4)
14	Corrientes	Corrientes (27° 28' S, 59° 53' W)	<i>A. albitalarsis</i> s.s. (A6)
15	Misiones	Posadas (27° 23' S, 55° 53' W)	<i>A. albitalarsis</i> s.s. (A5)
	Venezuela		
16	Portuguesa	Rio Bocono (8° 50' N, 69° 59' W)	<i>A. marajoara</i> (C14)

^a Individual specimen number in parentheses.

^b Type locality of *A. marajoara* (Galvão and Damasceno 1942).

^c Type locality of *A. deaneorum* (Rosa-Freitas 1989).

^d Type locality of *A. albitalarsis* (Lynch-Arribálzaga 1878).

et al. 1995a, b) further complicates determining the roles of each species in malaria transmission.

Although there has been recent progress on the identification of diagnostic primers from other molecular markers (ITS2; Li and Wilkerson 2005), species identification within the *Albitarsis* Complex currently relies on diagnostic RAPD bands as described in Wilkerson et al. (1995a, b), who used 19 decamer primers and found four species across Argentina, Brazil, Paraguay, and Venezuela: *A. albitalarsis* s.s., *A. marajoara* Galvão & Damasceno, *A. deaneorum*, and a fourth known as *A. albitalarsis* B that has yet to be formally described. These four species are predominantly allopatric, with sympatry recorded at nine of 32 collection localities (Wilkerson et al. 1995a). A recent study of the four members of the *Albitarsis* Complex based on a region of the *white* gene that includes both exon and intron sequence determined that only *An. marajoara* retains the fourth intron, which can provide a straightforward way of distinguishing this species from the other three (Merritt et al. 2005).

The objective of this study was to assess the RAPD-PCR methodology of Wilkerson et al. (1995a, b) as a species identification tool in *A. albitalarsis* s.l. by comparing the species identities resulting from RAPD diagnostic banding patterns with those from an independent marker, the mitochondrial DNA (mtDNA) cytochrome oxidase I (*COI*) gene. *COI* sequences have been shown to be useful in resolving evolutionary relationships among closely related species groups for a wide range of taxa (Avise 1994, 2000), including insects (Brown et al. 1994, Lunt et al. 1996) and anopheline mosquitoes (Krzywinski and Besansky 2003). The monophyly of the four putative species found by Wilkerson et al. (1995a, b) was tested to

determine whether they form phylogenetic species as defined by Nixon and Wheeler (1990).

Materials and Methods

Mosquito Collections and Species Identification. Collections (Table 1) were made between 1991 and 1998 from human landing catches, surfaces (blood-fed females resting indoors), or Shannon traps with collectors and propane lanterns as attractants. Because of the polytypic nature of the complex, specimens from or near the respective type localities are included: *A. albitalarsis*, Baradero (Buenos Aires), Argentina (Lynch-Arribálzaga 1878, Rosa-Freitas and Deane 1989); *A. deaneorum*, Guajará-Mirim (Rondônia), Brazil (Rosa-Freitas 1989); and *A. marajoara*, Ilha de Marajó (Pará), Brazil (actual: Cachoeira do Arari; Galvão and Damasceno 1942). *A. albitalarsis* B has yet to be formally described (Wilkerson et al. 1995a, b). All samples sequenced were from progeny broods as described in Wilkerson et al. (2005), and individuals from each family are retained as morphological vouchers in the Smithsonian Institution, National Museum of Natural History (NMNH). The lone sample from Portuguesa, Venezuela, collected by J.E.C. was a wild-caught female adult. DNA from this female is maintained at -80°C at the Conn Laboratory at the Wadsworth Center.

The morphological basis for the definition of the subgenus *Nyssorhynchus* is from Peyton et al. (1992). All species within the *Albitarsis* Complex were identified morphologically in the adult stage based on Linthicum (1988) or by using the methods described in Wilkerson et al. (1995b).

Total DNA was extracted from individuals using either the phenol-chloroform method described in Wilkerson et al. (1993) or the Puregene DNA isolation kit (Gentra Systems, Minneapolis, MN). For each specimen, species identification within the Albitarsis Complex was determined using the RAPD-PCR method of Wilkerson et al. (1995a, b). Individuals were labeled according to Wilkerson et al. (1995b) with species A as *A. albitarsis* s.s., B as *A. albitarsis* B, C as *A. marajoara*, and D as *A. deaneorum*.

Amplification and Sequencing of Mitochondrial DNA. The entire *COI* sequence was amplified using two sets of conserved primer pairs. The N-terminus of the gene was amplified using TY-J-1460 (annealing site located in the tRNA-Tyrosine coding region; 5'-TA-CAATTTATCGCCTAAACTTCAGCC-3'; Simon et al. 1994) and a modification of UEA-6 (5'-TTAATTC-CTGTAGGNACAGCAATAATTAT-3'; Zhang and Hewitt 1997). The COOH-terminus of the *COI* was amplified using modifications of C1-J-2195 (5'-TGAT-TYTTTGGTCATCCNGAAGT-3'; Simon et al. 1994) and TL2-N-3014 (5'-AATGCACTAATCTGCCATAT-TAG-3'; Simon et al. 1994). The PCR reactions were performed in 25- μ l volumes on a RoboCycler Gradient 96 Temperature Cycler (Stratagene, La Jolla, CA), each containing \approx 1/100 the DNA of a mosquito, 20 μ M each primer, and one Ready-To-Go PCR bead (GE Healthcare, Piscataway, NJ). An initial denaturation of 3 min at 95°C was followed by 35 cycles of amplification (1 min at 95°C, 1 min at 53°C, and 1 min at 72°C). The products were purified using CentriSpin 40 columns (Princeton Separations, Adelphia, NJ). The fragments were sequenced in both directions using ABI Prism BigDye version 1.0 Terminator cycle sequencing kit (Applied Biosystems, Foster City, CA) and run on the ABI Prism 377 automated sequencer (Applied Biosystems).

Nucleotide sequences were compiled, edited, and aligned by eye with the aid of Sequencher 3.0 (Gene Codes Corporation, Ann Arbor, MI). Aligned sequences were imported into PAUP* 4.0 (Swofford 2003). Sequences were aligned with the published *COI* DNA and protein sequence for *A. gambiae* (GenBank accession no. L20934; Beard et al. 1993) and translated into amino acids to ensure that the fragment sequenced was not a nuclear pseudogene. Sequences have been deposited into GenBank (accession nos. DQ076204–DQ076227, DQ076229–DQ076234).

Phylogenetic Analyses. Five to 14 individual mosquitoes per RAPD-PCR species were sequenced (Table 1). Two individuals of each of *A. darlingi* Root (GenBank accession nos. DQ076235 and DQ076236) and *A. braziliensis* Chagas (GenBank accession nos. DQ076237 and DQ076238) were included as outgroups. According to Linthicum (1988), *A. braziliensis* is the sister taxon to *A. albitarsis* and is the only other member of the Albitarsis group of the Argyritarsis section of *Nyssorhynchus*. This relationship was supported by Sallum et al. (2000) based on a cladistic analysis of 163 morphological characters. *A. darlingi* is a member of the Argyritarsis group within the Argy-

ritarsis section of *Nyssorhynchus* (Linthicum 1988) and was used as a more distant outgroup.

Both maximum parsimony (MP) and maximum likelihood (ML) analyses were implemented in PAUP* 4.0. Because of the number of ingroup taxa, optimal trees were generated using the heuristic search option with the tree bisection-reconnection (TBR) algorithm chosen for branch-swapping and multiple trees saved. For MP analysis, parsimony-uninformative characters were excluded, and 100 random-taxon-addition replicate analyses were carried out to identify multiple "islands" (Maddison 1991) of most parsimonious trees (MPTs). For ML analysis, an appropriate substitution model and model parameter values were determined using the computer program ModelTest 3.0 (Posada and Crandall 1998). This program generates and statistically evaluates using a standard likelihood ratio test the log likelihood scores for 14 substitution models. Uncorrected *p* and the genetic distance based on the ML model were calculated using PAUP* 4.0.

Nodal support was determined using nonparametric bootstrap proportion (Felsenstein 1985) and Bremer support (Bremer 1988). Under MP, bootstrap support values were generated by 1000 pseudoreplicates, with 10 random-taxon-addition replicates per pseudoreplicate, TBR branch swapping, and multiple trees saved. Five hundred pseudoreplicates were performed under ML, with a single random-taxon-addition starting tree per pseudoreplicate, nearest-neighbor-interchange (NNI) branch-swapping, and multiple trees saved; NNI branch-swapping was chosen to reduce computational time.

Under the MP framework, the Bremer support value or decay index (Bremer 1988) assesses nodal support by measuring the tree length of a tree constrained not to contain a particular node, subtracted from the unconstrained most parsimonious tree length. Index values measure the number of extra changes required on the tree for a branch to be lost; therefore, higher numbers generally indicate greater support at a node. Decay indices were calculated for each of the nodes present in the strict consensus of MPTs using the AutoDecay program, version 4.0.1 (Eriksson 1998).

Mr Bayes version 3.0 (Huelsenbeck and Ronquist 2000) also was used to evaluate optimal trees under a Bayesian phylogenetic framework. Program default values for the prior probabilities were used. The MCMC algorithm was allowed to run 300,000 generations, and sampled every 100 generations after a burn-in of 25,000 generations (250 trees). The log likelihood output of the chain was plotted to confirm that the chain had stabilized during the burn-in.

Statistical Tests. The optimal trees determined using both MP and ML are estimates of the true tree and may not be significantly different from other phylogenetic hypotheses. Several tests under both MP and ML were used to evaluate whether the optimal trees produced by *COI* sequence data were congruent with the evidence of four putative species identified using RAPD diagnostic markers. Constraint trees were created

with all four known species as monophyletic clades (within species branches were collapsed), with and without sister relationships assumed (*A. albitarsis* s.s./*A. albitarsis* B and *A. marajoara*/*A. deaneorum*; Wilkerson et al. 1995a).

Under the MP framework, the Templeton test (Templeton 1983) and the Kishino–Hasegawa (KH) test (Kishino and Hasegawa 1989) were used to determine whether MPTs were significantly shorter than the constraint trees. The Templeton test is a one-tailed Wilcoxon signed-rank test that compares the differences at each site in the number of substitutions required for each tree. The KH test is a *t*-test that compares the observed differences in number of steps between the two trees.

Under the ML criterion, both the KH and the Shimodaira–Hasegawa (SH) test (Shimodaira and Hasegawa 1999) were used to compare the likelihood scores of the ML tree with suboptimal trees found under constrained searches. Both KH and SH tests were performed using resampling estimated log-likelihood bootstrap (Goldman et al. 2000) with 10,000 replicates.

Results

Phylogenetic Analyses. Alignment of the *COI* DNA sequences produced homologous sequences of 1,470 bases in length with no observed indels. Of these, 297 (20.2%) sites were variable and 243 (16.5%) sites were parsimony informative. The strict consensus of 10 most parsimonious trees (MPTs; tree length, 528; consistency index [CI], 0.570; retention index [RI], 0.793) is shown in Fig. 1.

Using 1,470 characters from the ingroup, the best model of evolution fitting the sequence data were HKY + I + Γ . This model (Hasegawa et al. 1985) incorporated unequal base frequencies, a transition:transversion ratio (6.9875), proportion of invariant sites (0.7691), and the α shape parameter of the Γ distribution (0.9440). Using 1,470 homologous characters for both the ingroup and outgroups, one most probable tree was produced with a $-\ln$ likelihood score of 5148.5398 (Fig. 2).

For Bayesian analysis, a GTR + I + Γ model was used, with six categories of rates and estimated base frequencies. The strict consensus tree is shown in

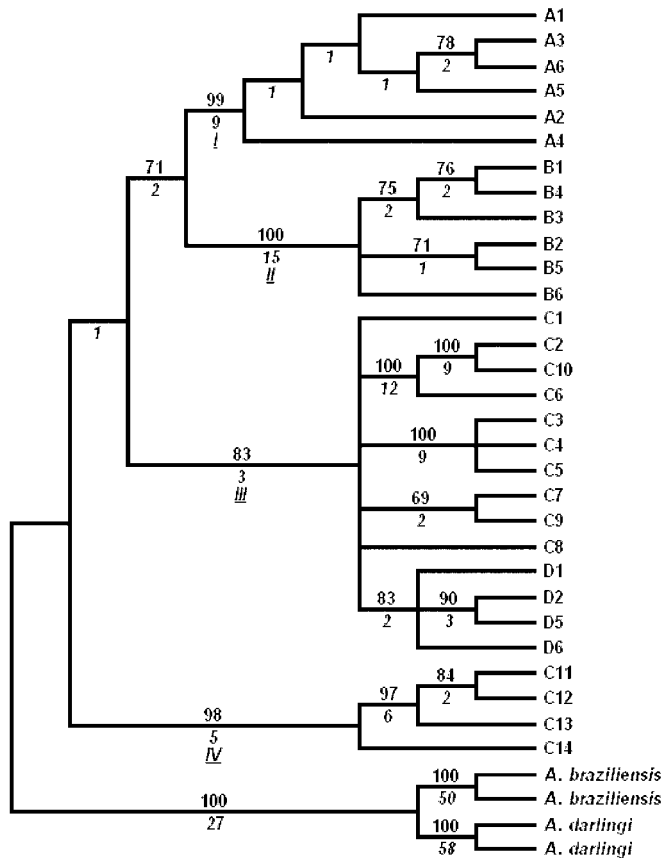

Fig. 1. Strict consensus of 14 equally parsimonious trees identified by *COI* DNA sequences. Numbers above branches indicate MP bootstrap proportions; numbers below the branches indicate Bremer support values. Clades I–IV are denoted in italics. Presumed identities (see text) are as follows: A, *A. albitarsis* s.s.; B, *A. albitarsis* B; C, *A. marajoara*; D, *A. deaneorum*; and E, undescribed. Outgroups are *A. braziliensis* and *A. darlingi*.

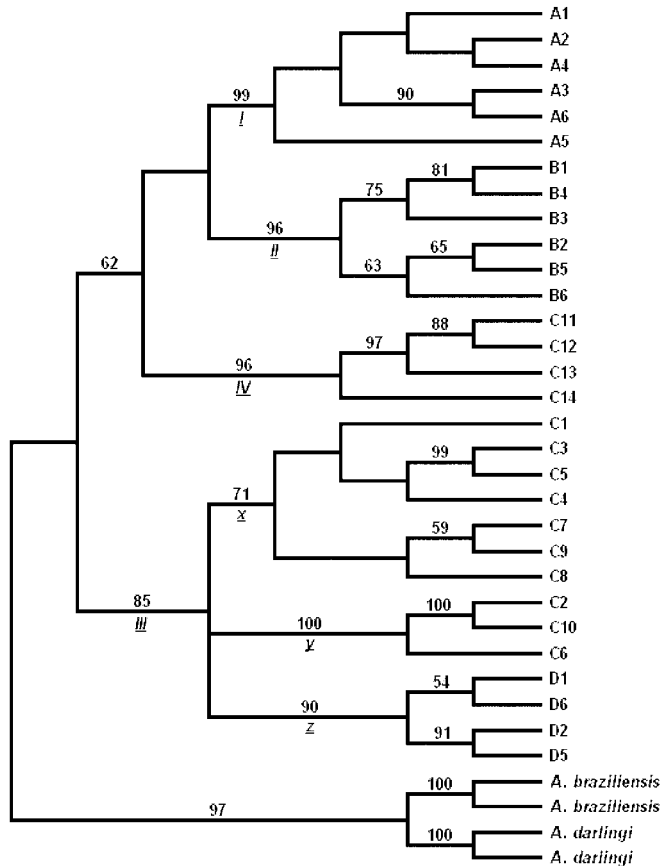

Fig. 2. Single tree identified by maximum likelihood analyses of *COI* DNA sequences under the HKY + I + Γ model of evolution. Numbers above branches indicate ML bootstrap proportions. Clades I–IV and x, y, z are denoted in italics. Presumed identities (see text) are as designated for Fig. 1.

Fig. 3. Log likelihood scores stabilized (plot not shown) within $\approx 10,000$ generations, well within the burn-in used for determination of posterior probabilities.

Monophyly of the *A. albitarsis* s.s., *A. albitarsis* B, and *A. deaneorum* species clades is strongly supported by MP (Fig. 1), ML (Fig. 2), and Bayesian (Fig. 3) analyses. Monophyly for *A. marajoara* as identified by RAPD diagnostic bands is not supported; this species is either polyphyletic or paraphyletic in all phylogenetic analysis.

Among all haplotypes within the Albitarsis Complex, mean (range) uncorrected p and HKY + I + Γ (d_{HKY}) were 0.0360 (0.0170–0.0490) and 0.0549 (0.0200–0.0870), respectively. Mean (range) p and d_{HKY} among all haplotypes identified as *A. marajoara* (C1–C14) by RAPDs was 0.0335 (0.0007–0.0531) and 0.0517 (0.007–0.0978), respectively. Pairwise genetic distances within and among each putative RAPD species and *A. marajoara* clades III (C1–C10) and IV (C11–C14) are shown in Table 2.

Topological Constraint Analyses. Eight optimal trees (not shown) were produced under the constraint of four monophyletic species within the Albi-

tarsis Complex (tree length, 538; CI, 0.559; and RI, 0.784). When hypothesized sister relationships of *A. albitarsis* s.s./*A. albitarsis* sp. B and *A. marajoara*/*A. deaneorum* were enforced with monophyletic species constrained, 34 optimal trees were produced (tree length, 597; CI, 0.601; and RI, 0.783). The 10 unconstrained MP trees were not significantly shorter than either the eight or the 34 constrained trees under either the Templeton or KH tests.

Topological constraints under the ML framework produced the same tree for both four monophyletic species with and without sister relationships enforced (not shown; $-\ln$ likelihood, 5172.0699). This tree was significantly less likely than the unconstrained best tree (difference in $-\ln$ likelihood, 23.5300; $P_{\text{KH test}} = 0.0168$, $P_{\text{SH test}} = 0.0127$).

Discussion

COI sequence data were useful in resolving some nodes within the Albitarsis Complex; however, deeper nodes are not well supported. Among MP, ML, and Bayesian methods, there was agreement in the grouping of individuals into at least four distinct monophy-

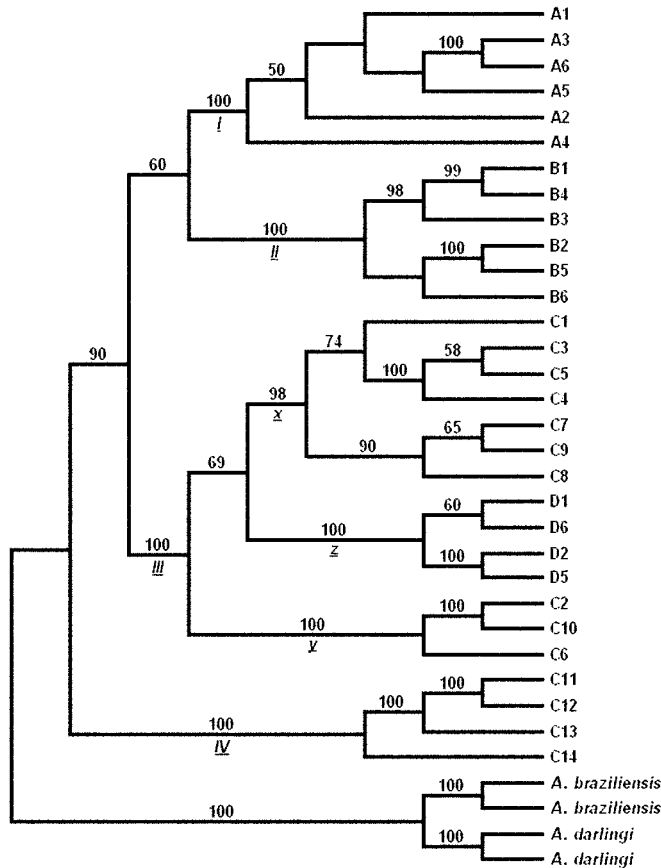

Fig. 3. Strict consensus of 2,751 trees identified by Bayesian analysis of *COI*DNA sequences under the GTR + I + Γ model of evolution. Numbers above branches indicate posterior probabilities. Clades I-IV and x, y, z are denoted in italics. Presumed identities (see text) are as designated for Fig. 1.

letic lineages with one paraphyletic group. Probably because of homoplasy, relationships between haplotypes and lineages lacked resolution under MP, and the Templeton and KH tests were not able to detect significant differences between the MP trees and constraint trees. Relationships among the lineages were better resolved in ML and Bayesian analyses, which incorporate information on differing substitution rates. ML demonstrated significant differences between the optimal tree and the constrained tree in statistical tests, with the optimal tree (showing *A. marajoara* as polyphyletic) being more likely given the *COI* sequence data.

There was moderate to strong support ($\geq 83\%$) for four lineages (clades I-IV; Figs. 1-3) within the Albitarsis Complex. In all phylogenetic analyses, *A. albitarsis* s.s. (A) and *A. albitarsis* B grouped together; however, this relationship was not well supported (bootstrap or posterior probability ranged from < 50 to 71). Both *A. albitarsis* s.s. (A) and *A. albitarsis* B, identified as separate species by fixed RAPD bands, form strongly supported reciprocally monophyletic clades and demonstrated range of genetic divergence (0.0259–0.0347 and 0.0336–0.0486 for p and d_{HKY} ,

respectively; Table 2) that was less than but comparable with the overall range observed among species (0.0170–0.0490 and 0.0200–0.0870 for p and d_{HKY} , respectively) within the Albitarsis Complex. Other support for the separate species status of *A. albitarsis* B can be based on a chromosomal species concept (fixed chromosomal inversions; Kreutzer et al. 1976, Steiner et al. 1982) and on a phenetic species concept (Steiner et al. 1982, Rosa-Freitas et al. 1990).

The morphospecies *A. marajoara* (based on RAPDs) seems to consist of at least two phylogenetic species. Either polyphyly or paraphyly of the group was observed in all phylogenetic analyses. In statistical tests under ML, the optimal tree showing the polyphyly of *A. marajoara* (C; Fig. 2) is significantly more likely than a constrained tree with *A. marajoara* monophyletic. Bremer support values indicate that eight or more steps would be required for *A. marajoara* to become a monophyletic clade. Moreover, the mean genetic distance within *A. marajoara* (all C haplotypes) (0.0335 and 0.0517 for p and d_{HKY} , respectively) is much larger than the within-species genetic distance values (0.0074–0.0134 and 0.0079–0.0154 for p and d_{HKY} , respectively) for *A. albitarsis* s.s., *A. al-*

Table 2. Average (range) pairwise genetic distance within and among *COI* haplotypes in the *Albitarsis* Complex

	<i>A. albitarsis</i> s.s.	<i>A. albitarsis</i> B	<i>A. marajoara</i>	<i>A. albitarsis</i> E	<i>A. deaneorum</i>
<i>A. albitarsis</i> s.s.	0.0097 (0.0048–0.0136) 0.0106 (0.0049–0.0152) 0.0406 (0.0336–0.0486)	0.0298 (0.0259–0.0347) 0.0074 (0.0007–0.0116) 0.0079 (0.0007–0.0127) 0.0656 (0.0490–0.0870)	0.0377 (0.0265–0.0469) 0.0405 (0.0340–0.0490) 0.0234 (0.0007–0.0367) 0.0310 (0.0007–0.0526) 0.0790 (0.0635–0.0978)	0.0406 (0.0367–0.0449) 0.0407 (0.0381–0.0531) 0.0467 (0.0408–0.0531) 0.0205 (0.0075–0.0272) 0.0259 (0.0079–0.0360) 0.0687 (0.0618–0.0808)	0.0330 (0.0293–0.0374) 0.0362 (0.0327–0.0401) 0.0260 (0.0170–0.0347) 0.0422 (0.0395–0.0456) 0.0134 (0.0109–0.0157) 0.0154 (0.0120–0.0185)
<i>A. albitarsis</i> B					
<i>A. marajoara</i>					
<i>A. albitarsis</i> E					
<i>A. deaneorum</i>					

Genetic distance based on *p* is above the diagonal; genetic distance based on HKY + I + Γ is below the diagonal.

bitarsis B, and *A. deaneorum* (Table 2). There are four individuals (C11–C14) that form a very strongly supported ($\geq 97\%$) monophyletic clade (clade IV; Figs. 1–3). The mean genetic distances (0.0467 and 0.079 for *p* and d_{HKY} , respectively) between *A. marajoara* of clade III (C1–C10) and clade IV are comparable with the genetic divergence found among the four putative species examined in this study (Table 2). Given the topology of all optimal trees under MP, ML, and Bayesian frameworks, the strong nodal support, and the amount of genetic divergence, clade IV represents a distinct phylogenetic species within the *Albitarsis* Complex (referred to as species E for the remainder of the discussion).

There has been previous genetic evidence in support of the existence of a different form (i.e., species E) in northern Brazil and Venezuela (Fig. 4). Based on fixed autosomal and X chromosomal inversions, Kreutzer et al. (1976) found three chromosomally differentiated populations within *A. albitarsis* s.l.; their form C found in Venezuela and Colombia seems to correspond to species E in this study. In addition, Rosa-Freitas et al. (1990) found evidence from allozyme loci of five groups based on Nei's genetic distance; their population iii found in Boa Vista (Roraima state, Brazil) seems to correspond to species E in this study. Because the diagnostic RAPD banding patterns for *A. marajoara* and species E are indistinguishable, Wilkerson et al. (1995a) identified all samples collected from Venezuela as *A. marajoara*. Despite finding some morphological differences from the description of Linthicum (1988) of *A. marajoara*, Rubio-Palis et al. (2003) have only identified *A. marajoara* among all *A. albitarsis* s.l. specimens collected in Venezuela because they used RAPDs for species identification.

A. deaneorum, which can be differentiated from *A. albitarsis* s.s. and *A. marajoara* by morphology and fixed RAPD bands, also forms a well-supported monophyletic clade within the *A. marajoara* lineage and differs genetically from the other three putative species with values ranging from 0.0170 to 0.0456 (*p*) and 0.0200–0.0808 (d_{HKY}). In all three phylogenetic analyses, however, *A. marajoara* (without species E) is not a strongly supported reciprocally monophyletic clade separate from *A. deaneorum*. There are three lineages within the *A. marajoara*/*A. deaneorum* clade (clade III) under both ML and Bayesian analyses (clades x, y, z; Figs. 2 and 3), whereas MP shows this clade to be polytomous. *Anopheles deaneorum* forms a strongly supported monophyletic clade (clade z) under ML and Bayesian analyses and a moderately supported monophyletic clade under MP. There is moderate bootstrap support under ML and strong support in the Bayesian analysis for a monophyletic clade containing C1, C3–5, and C7–9 (clade x). The remaining *A. marajoara* haplotypes (C2, C6, and C10) form a strongly supported monophyletic clade (clade y) under MP, ML, and Bayesian. The relationships among clades x, y, and z, however, are unresolved under ML and enigmatic in the Bayesian analysis. Mean genetic distances among *A. marajoara* haplotypes in clade III and between *A. marajoara* and *A. deaneorum* are congruent



Fig. 4. Geographical distribution of the five species in the Albitarsis Complex determined by *COI* DNA sequences. Numbers on map correspond to localities in Table 1.

with observed genetic distances between *A. albitarsis* and *A. albitarsis* B, which form good phylogenetic species.

There are two possible explanations for the genetic patterns and lack of resolution observed in the *A. marajoara*/*A. deaneorum* clade. The first is that *A. marajoara* from clade III may consist of at least two phylogenetic species. The monophyletic clade x (which includes C1 from the type locality of *A. marajoara*) is found in a geographically widespread band across Amazonia. Some *A. marajoara* haplotypes from clade y (C2 and C6) are found in sympatry with haplotypes from clade x (C3–5) in Itaituba. This divergence between the two clades may have occurred sympatrically because of reproductive isolation or it may be by predominantly allopatric divergence with secondary contact in Itaituba.

A second explanation is that *A. deaneorum* and *A. marajoara* are not separate species. Interestingly, both lineages are known to be involved in malaria transmission (Wilkerson et al. 2005), and our findings lend support to an hypothesis of potential introgression or shared ancestral polymorphisms for genes that would confer susceptibility to *Plasmodium*. *A. deaneorum*, as described by Rosa-Freitas (1989), is a morphospecies based primarily on a single character: branched outer anterior clypeal hairs in the larval

stage. This character seems to be invariant (R.C.W., unpublished data), and separation of *A. deaneorum* from other species in the Albitarsis Complex is further supported by allozyme loci, mtDNA, and hybridization studies (Rosa-Freitas et al. 1990, Narang et al. 1993, Lima et al. 2004).

There are seven diagnostic RAPD bands that are used to identify *A. marajoara* (Wilkerson et al. 1995a, b); however, the correlation of all seven bands in a single sample is not required for species identification (Wilkerson et al. 1995b). Commonly, the presence of two diagnostic bands is used to identify species. Bands shared by *A. marajoara* and species E may be because of amplification products from nonhomologous loci or amplification from areas conserved between the two species. A main assumption of the RAPD-PCR technique is that similarity of band size is a dependable indicator of homology; however, nonhomology of comigrating RAPD bands has been documented (Cognato et al. 1995, van de Zande and Bijlsma 1995, Rieseberg 1996). Among 220 pairs of comigrating fragments in wild sunflowers, Rieseberg (1996) found only 79.1% useful for comparative genetic studies; 91% of the bands exhibited cross-hybridization and/or displayed congruent restriction fragment profiles suggestive of homology; however, 13% of these loci mapped to incongruent genomic locations. The assumption of ho-

mology of similar sized fragments for RAPD-PCR, in particular, should be tested to determine the utility of the marker in phylogenetics and as a taxonomic tool.

Using two partial sequences of mtDNA *COI* and *ND4* genes and the rDNA ITS2 and D2 expansion regions, Wilkerson et al. (2005) used total evidence analysis with and without outgroups to examine relationships among members of the *Albitarsis* Complex. Their study and the present one both detected problems, using one or more analyses, with the phylogenetic status of *A. marajoara* and *A. deaneorum*. Despite the strong support for a potential fifth species in our study, we recognize that our findings are based on a single gene and that gene trees and species trees do not necessarily detect the same evolutionary trajectory (Presa et al. 2002). To better understand the species status of *A. marajoara* and *A. deaneorum*, we advocate the approach in Besansky et al. (2003) of a locus-by-locus assessment of members of species complexes.

Acknowledgments

We are especially grateful to M. M. Póvoa (Instituto Evandro Chagas/FUNASA in Belém, Brazil) for assistance in mosquito collection and logistics. D. Fonseca and C. Li provided assistance with RAPD identification. We thank L. Meehan for technical help. Some of the samples were sent to the Wadsworth Center Molecular Genetics Core for sequencing. Funding for this work was provided through National Institutes of Health grants (AI) R0154139 and TW09995-01 to J.E.C.

References Cited

- Avise, J. C. 1994. Molecular markers, natural history and evolution. Chapman & Hall, New York.
- Avise, J. C. 2000. Phylogeography. The history and formation of species. Harvard University Press, Cambridge, MA.
- Beard, C. B., D. M. Hamm, and F. H. Collins. 1993. The mitochondrial genome of the mosquito *Anopheles gambiae*: DNA sequence, genome organization, and comparisons with mitochondrial sequences of other insects. *Insect Mol. Biol.* 2: 103–124.
- Besansky, N. J., J. Krzywinski, T. Lehmann, F. Simard, M. Kern, O. Mukabayire, D. Fontenille, Y. Touré, and N. F. Sagnon. 2003. Semipermeable species boundaries between *Anopheles gambiae* and *Anopheles arabiensis*: evidence from multilocus DNA sequence variation. *Proc. Natl. Acad. Sci. U.S.A.* 100: 10818–10823.
- Black IV, W. C. 1993. PCR with arbitrary primers: approach with care. *Insect Mol. Biol.* 2: 1–6.
- Bremer, K. 1988. The limits of amino acid sequence data in angiosperm phylogenetic reconstruction. *Evolution* 42: 795–803.
- Brown, J. M., O. Pellmyr, J. N. Thompson, and R. G. Harrison. 1994. Phylogeny of *Greya* (Lepidoptera: Prodoxidae), based on nucleotide sequence variation in mitochondrial cytochrome oxidase I and II: congruence with morphological data. *Mol. Biol. Evol.* 11: 128–141.
- Clark, A. G., and C.M.S. Lanigan. 1993. Prospects for estimating nucleotide divergence with RAPDs. *Mol. Biol. Evol.* 10: 1096–1111.
- Cognato, A. I., S. O. Rogers, and S. A. Teale. 1995. Species diagnosis and phylogeny of the *Ips grandicollis* group (Coleoptera: Scolytidae) using random amplified polymorphic DNA. *Ann. Entomol. Soc. Am.* 88: 397–405.
- Eriksson, T. 1998. AutoDecay version 4.0.1. Distributed by the Author. Department of Botany, Stockholm University, Stockholm, Sweden.
- Felsenstein, J. 1985. Confidence limits of phylogeny: an approach using bootstrap. *Evolution* 39: 783–791.
- Galvão, A.L.A., and R. G. Damasceno. 1942. Sobre um novo anofelino da Ilha de Marajó, *Anopheles (N.) marajoara* n. sp. *Ann. Paul. Med. Cir.* 44: 424–427.
- Goldman, N., J. P. Anderson, and A. G. Rodrigo. 2000. Likelihood-based tests of topologies in phylogenetics. *Syst. Biol.* 49: 652–670.
- Hasegawa, M., H. Kishino, and T. Yano. 1985. Dating the human-ape splitting by a molecular clock of mitochondrial DNA. *J. Mol. Evol.* 22: 160–174.
- Huelsenbeck, J. P., and F. Ronquist. 2000. Mr Bayes: Bayesian inference of phylogeny. Distributed by the Author. Department of Biology, University of Rochester, Rochester, NY.
- Kengne, P., H. D. Trung, V. Baimai, M. Coosemans, and S. Manguin. 2001. A multiplex PCR-based method derived from random amplified polymorphic DNA (RAPD) markers for the identification of species of the *Anopheles minimus* group in Southeast Asia. *Insect Mol. Biol.* 10: 427–435.
- Kishino, H., and M. Hasegawa. 1989. Evaluation of the maximum likelihood estimate of the evolutionary tree topologies from DNA sequence data, and the branching order in hominoidea. *J. Mol. Evol.* 29: 170–179.
- Kreutzer, R. D., J. B. Kitzmiller, and M. G. Rabbani. 1976. Cytogenetically distinguishable sympatric and allopatric populations of the mosquito *Anopheles albitarsis*. *Acta Amaz.* 6: 473–481.
- Krzywinski, J., and N. J. Besansky. 2003. Molecular systematics of *Anopheles*: from subgenera to subpopulations. *Annu. Rev. Entomol.* 48: 111–139.
- Li, C., and R. C. Wilkerson. 2005. Identification of *Anopheles (Nyssorhynchus) albitarsis* complex species (Diptera: Culicidae) using ITS2-based PCR primers. *Mem. Inst. Oswaldo Cruz* (in press).
- Lima, J. B., D. Valle, and A. A. Peixoto. 2004. Analysis of reproductive isolation between sibling species *Anopheles albitarsis* sensu stricto and *Anopheles deaneorum*, two malaria vectors belonging to the *Albitarsis* complex (Diptera: Culicidae). *J. Med. Entomol.* 41: 888–893.
- Linthicum, K. J. 1988. A revision of the *Argyritarsis* section of the subgenus *Nyssorhynchus*, of *Anopheles*. *Mosq. Syst.* 20: 99–271.
- Lunt, D. H., D. X. Zhang, J. M. Szymura, and G. M. Hewitt. 1996. The insect cytochrome oxidase I gene: evolutionary patterns and conserved primers for phylogenetic studies. *Insect Mol. Biol.* 5: 153–165.
- Lynch, M., and B. G. Milligan. 1994. Analysis of population genetic structure with RAPD markers. *Mol. Ecol.* 3: 91–99.
- Lynch-Arribálzaga, F. 1878. Descripción de tres nuevos *Culicidae* de Buenos Aires. *Nat. Argent.* 1: 149–152.
- Maddison, W. P. 1991. The discovery and importance of multiple islands of most-parsimonious trees. *Syst. Zool.* 40: 315–328.
- Manguin, S., P. Kengne, L. Sonnier, R. E. Harbach, V. Baimai, H. D. Trung, and M. Coosemans. 2002. SCAR markers and multiplex PCR-based identification of isomorphic species in the *Anopheles dirus* complex in Southeast Asia. *Med. Vet. Entomol.* 16: 46–54.
- Manguin, S., R. C. Wilkerson, J. E. Conn, Y. Rubio-Palis, J. A. Danoff-Burg, and D. R. Roberts. 1999. Population structure of the primary malaria vector in South America,

- Anopheles darlingi, using isozyme, random amplified polymorphic DNA, internal transcribed spacer 2, and morphologic markers. *Am. J. Trop. Med. Hyg.* 60: 364–376.
- Merritt, T.J.S., C. R. Young, R. G. Vogt, R. C. Wilkerson, and J. M. Quattro. 2005. Intron retention identifies a malaria vector within the *Anopheles (Nyssorhynchus) albitarsis* complex (Diptera: Culicidae). *Mol. Phylogenet. Evol.* 35: 719–724.
- Muralidharan, K., and E. K. Wakeland. 1993. Concentration of primer and template qualitatively affects products in random-amplified polymorphic DNA PCR. *BioTechnology* 14: 362–364.
- Narang, S. K., T. A. Klein, O. P. Perera, J. B. Lima, and A. T. Tang. 1993. Genetic evidence for the existence of cryptic species in the *Anopheles albitarsis* complex in Brazil: allozymes and mitochondrial DNA restriction fragment length polymorphisms. *Biochem. Gen.* 31: 97–112.
- Nixon, K. C., and Q. D. Wheeler. 1990. An amplification of the phylogenetic species concept. *Cladistics* 6: 211–223.
- Peyton, E. L., R. C. Wilkerson, and R. E. Harbach. 1992. Comparative analysis of the subgenera *Kerteszia* and *Nyssorhynchus* of *Anopheles* (Diptera: Culicidae). *Mosq. Syst.* 24: 51–69.
- Posada, D., and K. A. Crandall. 1998. MODELTEST: testing the model of DNA substitution. *Bioinformatics* 14: 817–818.
- Posso, C. E., R. Gonzalez, H. Cardenas, G. Gallego, M. C. Duque, and M. F. Suarez. 2003. Random amplified polymorphic DNA analysis of *Anopheles numeztovari* (Diptera: Culicidae) from Western and northeastern Colombia. *Mem. Inst. Oswaldo Cruz* 98: 469–476.
- Presá, P., B. G. Pardo, P. Martínez, and L. Bernatchez. 2002. Phylogeographic congruence between mtDNA and rDNA ITS markers in brown trout. *Mol. Biol. Evol.* 9: 2161–2175.
- Riedy, M. F., W. J. Hamilton III, and C. F. Aquadro. 1992. Excess of non-parental bands in offspring from known primate pedigrees assayed using RAPD PCR. *Nucleic Acids Res.* 20: 918.
- Rieseberg, L. H. 1996. Homology among RAPD fragments in interspecific comparisons. *Mol. Ecol.* 5: 99–105.
- Rosa-Freitas, M. G. 1989. *Anopheles (Nyssorhynchus) deaneorum*: a new species in the *albitarsis* complex (Diptera: Culicidae). *Mem. Inst. Oswaldo Cruz* 84: 535–43.
- Rosa-Freitas, M. G., and L. M. Deane. 1989. The neotype of *Anopheles albitarsis* (Diptera: Culicidae). *Mem. Inst. Oswaldo Cruz* 84: 289–302.
- Rosa-Freitas, M. G., L. M. Deane, and H. Momen. 1990. A morphological, isoenzymatic and behavioural study of ten populations of *Anopheles (Nyssorhynchus) albitarsis* Lynch-Arribáizaga, 1878 (Diptera: Culicidae) including from the type-locality - Baradero, Argentina. *Mem. Inst. Oswaldo Cruz* 85: 275–289.
- Rosa-Freitas, M. G., R. Lourenço-de-Oliveira, C. J. de Carvalho-Pinto, C. Flores-Mendoza, and T. F. Silva-do-Nascimento. 1998. Anopheline species complexes in Brazil. Current knowledge of those related to malaria transmission. *Mem. Inst. Oswaldo Cruz* 93: 651–655.
- Rubio-Palis, Y., R. C. Wilkerson, and H. Guzman. 2003. Morphological characters of adult *Anopheles (Nyssorhynchus) marajoara* in Venezuela. *J. Am. Mosq. Control Assoc.* 19: 107–114.
- Sallum, M.A.M., T. R. Schultz, and R. C. Wilkerson. 2000. Phylogeny of Anophelinae based on morphological characters. *Ann. Entomol. Soc. Am.* 93: 745–775.
- Steiner, W., and A. Ender. 1993. Different thermostable DNA polymerases may amplify different RAPD products. *Nucleic Acids Res.* 21: 4647–4648.
- Shimodaira, H., and M. Hasegawa. 1999. Multiple comparisons of log-likelihoods with applications to phylogenetic inference. *Mol. Biol. Evol.* 16: 1114–1116.
- Simon, C., F. Frati, A. Beckenback, B. Crespi, H. Liu, and P. Flook. 1994. Evolution, weighting, and phylogenetic utility of mitochondrial gene sequences and a compilation of conserved PCR primers. *Ann. Entomol. Soc. Am.* 87: 651–701.
- Steiner, W. W.M., S. Narang, J. B. Kitzmiller, and D. L. Swofford. 1982. Genetic diversity and evolution in neotropical *Anopheles* (subgenus *Nyssorhynchus*), pp. 523–550. In W.W.M. Steiner, W. J. Tabachnick, K. S. Rai, and S. K. Narang [eds.], *Recent Developments in the Genetics of Insect Disease Vectors*. Stipes, Champaign, IL.
- Sucharit, S., and N. Komalamisra. 1997. Differentiation of *Anopheles minimus* species complex by RAPD-PCR technique. *J. Med. Assoc. Thailand* 80: 598–602.
- Swofford, D. L. 2003. PAUP*. Phylogenetic analysis using parsimony (* and other methods). Version 4. Sinauer, Sunderland, MA.
- Templeton, A. R. 1983. Phylogenetic inference from restriction endonuclease cleavage site maps with particular reference to the evolution of humans and the apes. *Evolution* 37: 221–244.
- van de Zande, L., and R. Bijlsma. 1995. Limitations of the RAPD technique in phylogeny reconstruction in *Drosophila*. *J. Evol. Biol.* 8: 645–656.
- Welsh, J., and M. McClelland. 1990. Fingerprinting genomes using PCR with arbitrary primers. *Nucleic Acids Res.* 18: 7213–7218.
- Wilkerson, R. C., T. J. Parsons, D. G. Albright, T. A. Klein, and M. J. Braun. 1993. Random amplified polymorphic DNA (RAPD) markers readily distinguish cryptic mosquito species (Diptera: Culicidae: *Anopheles*). *Insect Mol. Biol.* 1: 205–211.
- Wilkerson, R. C., T. V. Gaffigan, and J. Bento Lima. 1995a. Identification of species related to *Anopheles (Nyssorhynchus) albitarsis* by random amplified polymorphic DNA-polymerase chain reaction (Diptera: Culicidae). *Mem. Inst. Oswaldo Cruz* 90: 721–732.
- Wilkerson, R. C., T. J. Parsons, T. A. Klein, T. V. Gaffigan, E. Bergo, and J. Consolim. 1995b. Diagnosis by random amplified polymorphic DNA polymerase chain reaction of four cryptic species related to *Anopheles (Nyssorhynchus) albitarsis* (Diptera: Culicidae) from Paraguay, Argentina, and Brazil. *J. Med. Entomol.* 32: 697–704.
- Wilkerson, R.C., P. G. Foster, C. Li, and M.A.M. Sallum. 2005. Molecular phylogeny of the Neotropical *Anopheles (Nyssorhynchus) albitarsis* species complex (Diptera: Culicidae). *Ann. Entomol. Soc. Amer.* (in press).
- Williams, J.G.K., A. R. Kubelik, K. J. Livak, J. A. Rafalsky, and S. V. Tingey. 1990. DNA polymorphisms amplified by arbitrary primers are useful as genetic markers. *Nucleic Acids Res.* 18: 6530–6535.
- Zhang, D. X., and G. M. Hewitt. 1997. Assessment of the universality and utility of a set of conserved mitochondrial COI primers in insects. *Insect Mol. Biol.* 6: 143–150.
- Zhivotovsky, L. A. 1999. Estimating population structure in diploids with multilocus dominant DNA markers. *Mol. Ecol.* 8: 907–913.